ANNEX A: STATEMENT OF WORK (SOW): RFP/HCR/KAD/SUP/2022/07

1. Background

UNHCR implements activities aimed at strengthening protection and inclusion, especially of women from refugee, host, and IDP communities. From this perspective, one of the core activities is the construction of a motherhood & childhood center in the targeted location.

This Motherhood & childhood center contains the following:

- Consultation room.
- laboratory and pharmacy.
- Stabilization room (Temporary).
- Delivery & Antenatal Care room.
- Nutrition room.

With about 136 square meters of total building area, each motherhood & childhood center will contain general services facilities such as a latrine ('Ventilated improved pit latrine', considering gender diversity and people with disabilities) with hand washing basins.

Concerning water supply, an elevated water tank supplied from a connection pipeline from the nearest water yard will be installed, and those centers will be electrically powered using solar energy.

In the design of the motherhood & childhood center a lot of consideration related to the protection of disabled people was taken to facilitate their movement, Ramps with handrails, even in latrine there is one instance especially designed for people with disabilities.

This Statement of Work (SOW) describes in detail the required works Motherhood & Childhood care center in Gubyeish.

2. General Information

- The contractor should visit the sites before submitting the offer and get acquainted with the type of work required, the nature of the area, securing of supplying materials to the site, and keeping them stored safely.
- The contractor shall submit samples/descriptions/specifications of the materials to be used in the project to the UNHCR supervisor engineer, for approval, before the commencement of works.
- The supervisor engineer can reject any material that will not comply with the specifications, and replace it by the contractor without extra cost, or the supervisor engineer can ask for any test to ensure the quality of the material used and work.
- The contractor has no right to change or draw any samples or materials being submitted and approved from the site without written permission from the supervisor engineer.
- Work should be completed within a period of (90) days, ninety calendar days.
- The contractor shall commence working within 7 calendar days from the date of signature of the contract and delivering the site.
- After completion of works, a guarantee period of six (06) calendar months for the construction component, and 2 calendar years for the solarization component shall apply.
- All works will be supervised by a supervisor engineer or supervisor engineers nominated by UNHCR.
- The contractor shall appoint a qualified supervisor construction engineer with at least three years of professional experience to work full-time on the site during the contract period.
- The contractor shall prepare a detailed plan of the works upon handover of the site and signing of contract before commencement of the work and should as well submit periodically progress reports to the supervisor engineers of UNHCR.
- The workmanship will be assessed after completion, upon which UNHCR will consider further cooperation with the company involved.

- The site shall be handed over in a clean environment condition.

3. Scope of Work.

The Scope of Work has undertaken the following:

1. Construction Works:

- 1.1. The contractor should Mobilize his labor, a mobile workshop to be used for fixing maintaining, and repairing any kind of work such as steel, carpentry ...etc.
- 1.2. The contractor should do Clearing for the site after completing the whole Job and before handover.
- 1.3. Excavation Works:
 - 1.3.1. The contractor should perform Excavation to the required depth for foundation 50(width)*70(depth)cm with disposal of excavation away or selected approved area.
- 1.4. Foundation Works:
 - 1.4.1. The contractor should Supply material and lay the stone foundation with c/s mortar (1:8) 50 cm depth by 2 stages 25 cm each.
- 1.5. The contractor should Supply materials and building brick continue foundation (two bricks system) with c/s mortar (1:6) width of wall 40cm, Hight 40 cm.
- 1.6. Concrete Works:
 - 1.6.1. The contractor should Supply materials and cast reinforced concrete (1:2:4) with 6 steel 12mm bar and use 8mm steel bar for Stirrup for continuous foundation 30*40cm, including conc. Steel, formation work, steel work, and related works.
 - 1.6.2. The contractor should Supply materials and cast reinforced concrete (1:2:4) with 4Ø12mm steel bars and use 8mm steel bar for Stirrup for tie beams 30*20cm, including concrete, steel, formwork, steel work, and all related works.
 - 1.6.3. The contractor should Supply materials and cast reinforced concrete (1:2:4) with 4Ø12mm steel bars and use an 8mm steel bar for Stirrup for ring beam 30*20cm, including concrete, steel, formwork, steel work, and all related works.
- 1.7. Masonry Works:
 - 1.7.1. The contractor should Supply materials and build a brick wall of red bricks with c/c mortar (1:8) width of 30cm (one and a half brick system) including parapet, work to include all related works.
- 1.8. Floor Works:
 - 1.8.1. The contractor should supply materials and fill the subbase layer of selected material underground slab of 40cm, including leveling, watering, and compaction by 2-layer 20cm each.
 - 1.8.2. The contractor should supply materials and cast 10 cm thick concrete (1:3:6) for the ground slab, work including all related works.
- 1.9. Finishing Works:
 - 1.9.1. The contractor should supply materials and plaster walls c/s mortar (1:6) for internal and external walls, including walls edge /corners plaster windows and doors sills and all related works, complete job.

- 1.9.2. The contractor should supply materials and apply quick drying prime (internal walls only) two coats to make the surface of walls adhesive to receive new paint.
 - 1.9.3. The contractor should supply materials and apply paint (suitable for interior and exterior walls) and 2 layers of paint (selected color) (main blocks).
- 1.10. Roof Works:
- 1.10.1. The contractor should supply materials and fabricate a steel grid from rectangular steel pipes 4*8 cm and 6*3 cm 1mm, for roof support grids, the work includes fixing anti-rust paint, paint, fixing the tie beams using bolts and all necessary accessories the work includes supply materials and fix a pre-painted corrugated sheets steel sheets .35mm the blue color, as shown in the design, fixing on the purlins, trusses drilled nails with washer and all necessary accessories.
 - 1.10.2. The contractor should supply and fix the suspended ceiling from gypsum board square tiles 60x 60 cm, Aluminum frames T profile, and the suspended hanging system, including aluminum L profile. sample to be presented prior to installation.
- 1.11. Doors and Windows:
- 1.11.1. The contractor should supply and fix (180*220) size new solid steel door, locally made, using heavy steel for door and frames as in attached design, covered with heavy steel sheet, price to include, fixing with hinges, locking system, painted., as per normal standard and UNHCR engineer instruction.
 - 1.11.2. The contractor should supply and fix (120*220) size new solid steel door, locally made, using heavy steel for rectangular pipes for doors and frames as in attached design, covered with heavy steel sheet, price to include, fixing with hinges, locking system, painted., as per normal standard and UNHCR engineer instruction.
 - 1.11.3. The contractor should supply and fix (3*220) size new solid steel door for the main gate, locally made, using heavy steel for door and frames as in attached design, covered with heavy steel sheet, price to include, fixing with hinges, locking system, paint, etc., as per normal standard and UNHCR engineer instruction.
 - 1.11.4. The contractor should supply material and fabricate (120*120) size new steel windows, locally made, using heavy steel for frames, covered with a ribbed steel plate with horizontal grills made of 4*8 cm pipes, price to include, fixing with hinges, locking system, paint, grills ...etc., as per normal standard and UNHCR engineer instruction.
- 1.12. Electrical Works:
- 1.12.1. The contractor should provide for supply, installation, and all cables required for complete electrical work including PVC conduits.
 - 1.12.2. The contractor should supply and install Ceiling mounted sweep fan with all Accessories like wall-mounted Speed Control, non-corrosive type blades, regulator, fan hook, extension rod, and all other accessories required. The minimum fan-to-floor distance shall be 230cm. The price shall include PVC insulated conductors of 3x2.5mm² inside PVC conduit of 16mm diameter including junction boxes with covers and insulating screw cap connectors The work should include excavation, laying, and connection with cable cleats, the works include supplying and installing all needed accessories.

- 1.12.3. The contractor should supply, install and connect wall lights of LED from approved type 15 w in buildings as shown in the drawings with the wiring of 2x2.5mm² cable inside PVC conduit of 16mm diameter to, the work includes digging installing (installation before finishing works) and needed finishing works."
- 1.12.4. The contractor should supply and install an approved type of LED roof light lamp Lighting, 15W the works include supplying and installing all needed accessories.
- 1.13. Fence Works:
- 1.13.1. The contractor should Supply material and fabricate a chain link fence, 1.8-meter height. 3" steel pipes supporter @ meters, fixed by 30 cm concrete base including all related works, especially the main and minor gates, as shown in drawings.
- 1.14. The contractor should supply material and fill the sub-base layer of selected materials for the corridor (at the entrance), 40 cm height, rate includes leveling, watering, and compaction by 2 layers 20 cm each, as per normal standard and UNHCR engineer instruction.
- 1.15. The contractor should supply materials and cast conc.3 Steps 150cm wide and 15 cm height @ (entrance), with length 3m, rate includes all related works, as per normal standard and UNHCR engineer instruction.
- 1.16. The contractor must supply materials and cast Construct 1 ramp for disabled people as shown in the drawing, with a slope of 1:08 a maximum length of 3.5-4 meters, and a width not less than 90 cm, handrails should also be installed to protect and facilitate the use of ramps, the work includes site cleaning before and after construction and all necessary finishing works, as per normal standard and UNHCR engineer instruction.
- 1.17. Latrines (5 Stances):
- 1.17.1. The contractor should perform excavation work of the pit with dimensions (3*3*6) m, the work includes disposal of excavated materials to an approved area away from the site location.
- 1.17.2. The contractor should supply and construct a pit lining with (1.5) bricks with cement mortar (1:8) including dividing walls.
- 1.17.3. The contractor should supply and cast concrete (1:3:6) for the pit and floors (10cm) and make cement coating.
- 1.17.4. The contractor should supply and make a plaster with cement mortar (1:6) for the inside of the pit.
- 1.17.5. The contractor should perform excavation of the foundation trench (0.5*0.5), the work includes disposal of excavated materials to an approved area away from the site location.
- 1.17.6. The contractor should supply and construct a single-brick wall with cement mortar (1:8) for rooms (including divided walls).
- 1.17.7. The contractor should supply and a cast of concrete (1:2:4) for the door's beam reinforced with steel bars 12mm (4 bars).
- 1.17.8. The contractor should supply, manufacture, and installation of zinc roofing corrugated steel sheet with 0.35 mm thick fixed by square pipes (4*8) including fixing bolts (4*8), the work

includes pre-painting, fixing on the rafters using all necessary plates, bolts, welding, and accessories.

1.17.9. The contractor should supply and making plaster with cement mortar (1:8) for the walls inside and outside the rooms, isolation walls and all parapets.

1.17.10. The contractor should supply and install steel doors with a skylight size (0.7 * 2.2) meters for the doors of normal rooms.

1.17.11. The contractor should supply and install of a steel door with a skylight size (1*2.2) meters for people with special needs room.

1.17.12. The contractor should supply and paint the wall inside and out (color is white with a blue stripe on the top line).

1.17.13. The contractor should supply and install of ventilation pipes with cover for each stance.

1.17.14. The contractor should supply and install facilities for people with disabilities:

- Iron seat.
- Ceramic hand washing basin.
- Handrail along the room.

1.17.15. The contractor should supply and install toilet ceramic seats of an approved type.

1.17.16. The contractor should supply material and construct a sub-base layer of selected material under the corridor ground slab of 35 cm, work includes leveling and compaction.

1.17.17. The contractor should supply materials and cast 10 cm thick plain concrete (1:3:6) for the corridor slab.

1.17.18. The contractor should construct of a ramp to the special needs people's room with a handrail.

1.17.19. The contractor should supply materials and build 2 basins for hand washing attached to latrines, with 2 water taps, the height should be suitable for disabled people, the work includes piping from the elevated water tank located in the women's center with all needed fittings.

1.17.20. The Contractor should supply materials and build 2 basins for hand washing attached to latrines, with 2 water taps, the height should be suitable to disabled people, the work includes piping from the elevated water tank located in the women's center with all needed fittings, as per normal standard and UNHCR engineer instruction.

1.18. External Floor Works:

The contractor should Supply materials and backfill the compound to ensure floor protection with a selected material height of 30cm, a rate include leveling and compaction.

1.19. Feasibility Works:

The contractor should Supply and install a signboard (1 * 1) of meters of iron sheet, indicating the name of the project, the donor, and the implementer, the signboard should fix in a way to be visible.

2. Solarization Works:

2.1. General Objectives:

The work includes the furnishings of materials, consumable materials, facilities, civil works, labor, tools, equipment, test instruments, apparatus, specialties, and other services necessary to complete the installation and commissioning of the solar system at the UNHCR above-mentioned facility (in Ghubash), which should include all peripheral equipment system necessary for the completion of the project.

The contractor shall be responsible for any additional electrical power requirements with the coordination and approval of UNHCR.

The contractor shall submit the following documentation to UNHCR upon completion of the project:

- System brochures/documentation for systems operational & Maintenance/User Manuals. Detailed equipment list stating the location, make model, serial numbers, and firmware.
- Result of system test as per manufacturer standards
- System and Workmanship Warranty/Guarantee

2.2. Maintenance Proposals:

- Certification of parts availability and support for One [1] year.
- Training Certification of attendees for Operations and Maintenance of the system.

2.3. Installation:

The contractor shall perform the installation, testing, and commissioning of all equipment. All necessary tests, services, and inspections to ensure the solar system's function shall be checked and approved before the acceptance test. The proposal shall include a detailed schedule so as not to cause interruptions in the operation of UNHCR.

The contractor shall prepare and furnish fully dimensioned scaled drawings of the builder's work arising from the installation of the equipment and system as well as for the equipment layout plans at various locations.

2.4. Training and Knowledge Transfer:

The technical staff shall give the trainees detailed knowledge of the technical functions. Upon completion of the training, the trainees shall be able to perform tests of the system, to maintain the system.

2.5. Inspection and Testing:

Before the final acceptance of the work, the contractor shall test the system to demonstrate compliance with contract requirements.

The whole system shall be subjected to complete functional and operational tests.

When these tests have been completed and corrections made as necessary, the contractor shall submit a signed and dated certificate with a request for formal inspection and test.

2.6. Warranty:

Upon completion and before final acceptance of the work, the contractor/supplier shall furnish UNHCR with a written guarantee, stating that all works executed under this project are free from material defects and workmanship; and the guarantee for supplied equipment shall have a period of at least two (2) years inclusive of labor, transportation, and expenses that are needed for the repair/replacement of defective equipment.

4. Bill of Quantity (BOQ)

The specified job is all provisional, including the provision of materials and workmanship, providing water and electricity for the implementation and all other requirements to implement the job perfectly. The cost of this item should be included /embedded in the other items. Below is the BOQ:

No.	DESCRIPTION	UNIT	QTY
1.0	MOBILIZATION		
1.1	Mobilization and Demobilization of labor/machinery workshop for fixing, fabrication, and maintaining of any kind of work such as formworks, concrete, steel, carpentry ...etc.	JOB	1
2.0	SITE CLEARANCE		
2.1	Cleaning the site after completing the whole job and before handover.	JOB	1
3.0	BUILDINGS WORKS		
3.1	Excavation required depth for foundation 50(width)*70(depth)cm, rate including disposal of excavation away or selected approved area, as per normal standard and UNHCR engineer instruction.	ML	88
3.2	supply material and lay a stone foundation with c/s mortar (1:8) (50 cm depth, 50 cm width) by 2 stages 25 cm each as per normal standard and UNHCR engineer instruction.	ML	88
3.3	Supply materials and building brick continue foundation (two bricks system) with c/s mortar (1:6) width of wall 40cm, height 40 cm, as per normal standard and UNHCR engineer instruction.	ML	88
3.4	Supply materials and cast reinforced concrete (1:2:4) with 6 steel 12mm bar for Grade beam 30*40cm and use 8mm steel bar for Stirrup @ 200 mm, the rate to include conc. Steel, formation work, steel work, and related works, as per normal standard and UNHCR engineer instruction.	M3	10.56
3.5	Supply materials and build bricks wall of blocks with c/c mortar (1:8) width of 30cm (one and a half brick system) including parapet, work to include all related works, as per normal standard and UNHCR engineer instruction.	M2	264
3.6	Supply materials and cast reinforced concrete (1:2:4) with 4 ϕ 12mm steel bars for tie beams 30*20cm and use 8mm steel bar for Stirrup @ 200 mm, rate to include concrete, steel, formwork, steel work, and all related works, as per normal standard and UNHCR engineer instruction.	M3	5.28
3.7	Supply materials and cast reinforced concrete (1:2:4) with 4 ϕ 12mm steel bars for ring beam 30*20cm and use 8mm steel bar for Stirrup @ 200 mm, rate to include concrete, steel, formwork, steel work, and all related works, as per normal standard and UNHCR engineer instruction.	M3	5.28
3.8	Supply materials and fill the sub-base layer of a selected material underground slab (for the rooms and waiting area) of 40cm, rate including leveling, watering, and compaction by 2 layers 20cm each, as per normal standard and UNHCR engineer instruction.	M3	54.4
3.9	Supply materials and cast 10 cm thick concrete (1:3:6) for ground slab including steel grid with 8 mm steel bars at 20 cm in both directions (including the waiting area) work includes all related works, as per normal standard and UNHCR engineer instruction.	M2	136
3.10	Supply materials and plaster walls c/s mortar (1:6) for internal and external walls, rate include walls edge /corners plaster windows and doors sills and all related works, complete job, as per normal standard and UNHCR engineer instruction.	M2	446

3.11	supply materials and fabricate steel grid from rectangular steel pipes 4*8 cm and 6*3 cm 1mm, for roof support grids, the work includes fixing, unit rust paint, paint, fixing on the tie beams using bolts and all necessary accessories the work includes supply materials and fix a pre-painted corrugated sheets steel sheets .35mm blue colour, as shown in the design, fixing on the purlins, trusses drilled nails with washer and all necessary accessories, as per normal standard and UNHCR engineer instruction.	M2	136
3.12	Supply and fix suspended ceiling from gypsum board square tiles 60x 60 cm, Aluminium frames T profile, and the suspended hanging system, including aluminum L profile. The sample is to be presented a prior installation, as per normal standard and UNHCR engineer instruction.	M2	136
3.13	Supply and fix 600x600mm Heavy Duty, water resistant, glazed ceramic. The sample is to be presented prior to installation, as per normal standard and UNHCR engineer instruction.	M2	136
4.0	DOORS AND WINDOWS		
4.1	Supply and fix (180*220) size new solid steel door, locally made, using heavy steel for door and frames as in attached design, covered with heavy steel sheet, price to include, fixing with hinges, locking system, paint..etc, as per normal standard and UNHCR engineer instruction.	NO.	2
4.2	Supply and fix (120*220) size new solid steel door, locally made, using heavy steel for rectangular pipes for doors and frames as in attached design, covered with heavy steel sheet, price to include, fixing with hinges, locking system, paint,...etc, as per normal standard and UNHCR engineer instruction.	NO.	3
4.3	Supply and fix (3*220) size new solid steel door for the main gate, locally made, using heavy steel for door and frames as in attached design, covered with heavy steel sheet, price to include, fixing with hinges, locking system, paint,...etc, as per normal standard and UNHCR engineer instruction.	NO.	1
4.4	Supply material and fabricate (120*120) size new steel new windows, locally made, using heavy steel for frames, covered with a ribbed steel plate with horizontal grills made of 4*8 cm pipes, price to include, fixing with hinges, locking system, paint, grills ...etc, as per normal standard and UNHCR engineer instruction.	NO.	23
5.0	FINISHING WORKS		
5.1	Supply materials and apply quick drying prime (internal walls only) two coats to make the surface of walls adhesive to receive new paint, as per normal standard and UNHCR engineer instruction.	M2	264
5.2	Supply materials and apply paint (suitable for interior and exterior walls) 2 layers of paint (selected color) (main blocks), rate includes all related works, as per normal standard and UNHCR engineer instruction.	M2	446
6.0	ELECTRICAL WORKS & EXTRA FINISHING WORKS		
6.1	Provide for supply, installation, and all cables and sockets (as sown in drawings) required for complete electrical work including PVC conduits Provide for armored connection cable from the building to the nearest power source. The rate should include excavation, laying, and connection with cable cleats, as per normal standards and UNHCR engineer instruction.	LS	1
6.2	Supply and install Ceiling mounted sweep fan with all Accessories like wall-mounted Speed Control, non-corrosive type blades, regulator, fan hook, extension rod, and all other accessories required. The minimum fan-to-floor distance shall be 230cm. The price shall include PVC insulated conductors of 3x2.5mm ² inside PVC conduit of 16mm diameter including junction boxes with covers and insulating screw cap connectors The rate should include excavation, laying, and connection with cable cleats, as per normal standard and	LS	13

	UNHCR engineer instruction.		
6.3	Light Fittings and Lamps: supply, install and connect wall lights of LED Wall lamps 15 w in buildings as shown in the drawings with the wiring of 2x2.5mm ² cable inside PVC conduit of 16mm diameter, the work includes digging installing (installation before finishing works), lamps key for opening and closing, and all needed finishing works, as per normal standard and UNHCR engineer instruction.	LS	30
6.4	Supply and install an approved type of LED roof light lamps Lighting, 15W, The rate should include fixing the on the roof, wiring, laying and connection with cable cleats and lamps key for opening and closing, as per normal standard and UNHCR engineer instruction.	LS	20
6.5	Supply material and fill sub-base layer of selected materials for the corridor (at the entrance), 40 cm height, rate includes leveling, watering and compaction by 2 layers 20 cm each, as per normal standard and UNHCR engineer instruction.	M3	14.4
6.6	Supply materials and cast conc.3 Steps 150cm wide and 15 cm height @ (entrance), with length 3m, rate includes all related works, as per normal standard and UNHCR engineer instruction.	LS	1
6.7	Supply materials and cast Construct 2 ramps for disabled people as shown in the drawing, with a slope of 1:08 with a maximum length of 3.5-4 meters and a width not less than 90 cm, Using 8mm steel bars, 15 cm mesh both directions as fine reinforcement, handrails should also be installed to protect and facilitate the use of ramps, the work includes site cleaning before and after construction and all necessary finishing works, as per normal standard and UNHCR engineer instruction.	LS	1
7.0	FENCE WORKS		
7.1	Supply material and fabricate chain link fence as shown in the drawing, 1.8-meter height. 3" steel pipes supporter @ 2 meters, fixed by 40x40x50 cm concrete base rate attached to wire mesh 25cm and linked to steel pipes using Knot every 1m to ensure good fixing as shown in drawings, as per normal standard and UNHCR engineer instruction.	ML	100
7.2	Supply material and fabricate the main gate with a locking system linked to the fence as shown in the drawing,3m width (2 doors with support and lock in the middle), 1.8-meter height. 3" steel pipes for both frame and stands, fixed by 60x60x60 cm concrete base, rate including all needed works, as per normal standard and UNHCR engineer instruction.	LS	1
7.3	Supply material and fabricate pedestrian gate linked to the fence as shown in the drawing,1.2m width, 1.8-meter height. 3" steel pipes for both frame and stands, fixed by 60x60x60 cm concrete base rate including all needed works as per normal standard and UNHCR engineer instruction.	LS	1
8.0	LATRINE (5 STANCE)		
8.1	excavation of pit with dimensions (3*3*6) m, the work includes disposal of excavated materials to an approved area away from site location, as per normal standard and UNHCR engineer instruction.	M3	54
8.2	Supply and construction of a pit lining with (1.5) bricks with cement mortar (1:8) including dividing walls, as per normal standard and UNHCR engineer instruction.	M2	63
8.3	Supplying and casting concrete (1:3:6) for the pit and floors (10cm) and making Cement coating, as per normal standard and UNHCR engineer instruction.	M2	26
8.4	Supplying and placing Reinforcement concrete (1:2:4) for the latrine slab using 12mm bars 12cm grid c/c for reinforcement, as per normal standard and UNHCR engineer instruction.	M2	18
8.5	supplying and making a plaster with cement mortar (1:6) for the inside of the pit, as per normal standard and UNHCR engineer instruction.	M2	90

8.6	Excavation of foundation trench (0.5*0.5), the work includes disposal of excavated materials to an approved area away from the site location, as per normal standard and UNHCR engineer instruction.	ML	40
8.7	Supply and construction of a single-brick wall with cement mortar (1:8) for rooms (including divides walls), as per normal standard and UNHCR engineer instruction.	M2	67.5
8.8	Supply and casting of concrete (1:2:4) for the door beam reinforced with steel bars 12mm (4 bars), as per normal standard and UNHCR engineer instruction.	ML	24
8.9	Supply, manufacture, and installation of zinc roofing corrugated steel sheet with 0.35 mm thick fixed by square pipes (4*8) including fixing bolts (4*8) the work includes pre-painting, fixing on the rafters using all necessary plates, bolts, welding, and accessories, as per normal standard and UNHCR engineer instruction.	M2	15
8.10	Supplying and making plaster with cement mortar (1:8) for the walls inside and outside the rooms, isolation walls, and all parapets, as per normal standard and UNHCR engineer instruction.	M2	126
8.11	Supplying and installing steel doors with a skylight size (0.7 * 2.2) meters for the doors of normal rooms, as per normal standard and UNHCR engineer instruction.	No	4
8.12	Supply and installation of a steel door with a skylight size (1*2.2) meters for people with special needs room, as per normal standard and UNHCR engineer instruction.	No	1
8.13	Supplying and painting the wall inside and out (color is white with a blue stripe on the top line, as per normal standard and UNHCR engineer instruction.	M2	126
8.14	Supply and installation of ventilation pipes with meshed cover.	No	5.0
8.15	Supplying and installing facilities for people with disabilities, -iron seat, -handrail along the room. as per normal standard and UNHCR engineer instruction.	LS	1.0
8.16	Supplying and installing toilet ceramic seats of an approved type, as per normal standard and UNHCR engineer instruction.	No	5.0
8.17	Supply material and construct a sub-base layer of selected material under the corridor ground slab of 35 cm, work includes leveling and compaction, as per normal standard and UNHCR engineer instruction.	M3	4.0
8.18	Supply materials and cast 10 cm thick plain concrete (1:3:6) for corridor slab, as per normal standard and UNHCR engineer instruction.	M3	1.5
8.19	Supply and construction of a ramp to special need people room with handrail, as per normal standard and UNHCR engineer instruction.	No	1.0
9.0	EXTERNAL FLOOR		
9.1	Supply materials and backfill of the compound to ensure floor protection with a selected material height of 30cm, rate including leveling and compaction, as per normal standard and UNHCR engineer instruction.	M2	188
10.0	HANDWASHING BASIN		
10.1	Supply materials and buildbasinssin for hand washing attached to latrines, with 2 water taps, the height should be suitable to disabled people, the work includes piping from the elevated water tank located in the women’s center with all needed fittings, as per normal standard and UNHCR engineer instruction.	LS	1.0
11.0	FEASIBILITY WORKS		
11.1	Supplying and installing a signboard (1 * 1) of meters of iron sheet, indicating the name of the project, the donor, and the implementer, as per normal standard and UNHCR engineer	No	1.0

	instruction.		
12.0	SOLARIZATION WORKS		
12.1	<p>Solar Panels:</p> <p>Supply & installation of robust 330-watt peak 24 volts,8,8 Amp, solar panels must have one of these ISO, CE RoHS, UL, IEC, and TUV Certificates.</p> <p>Each PV module deployed must identification tag which should be able to withstand harsh environmental conditions and consist of the following information:</p> <ul style="list-style-type: none"> * Name of the manufacturer of the Solar panels. (PV modules) * Month and year of manufacture for each solar Panel. * Panel (Module) Wattage, I_{max}, V_{max}, FF ...etc. * Unique serial number of the Panels (PV modules). 	Pcs	14
12.2	<p>Batteries:</p> <p>Supply Led Acid (GEL) deep cycle batteries,200 Ah 12- Volt. & Batteries must have one of these accreditation certificates such as ISO, CE, RoHS, IEC...etc. Or has passed the UNDP lab test (Sudan).</p> <p>They must be manufactured at most in the latest (06) six months.</p>	Pcs	16
12.3	<p>Inverter:</p> <p>Supply & install with capacity power 5000 VA, Volt 48 V rated, The Inverter must meet one of these, ISO, CE, RoHS, IEC Certificates.</p> <p>The Inverter must meet below:</p> <ul style="list-style-type: none"> *Charge controller MPPT build-in. * Output details: Pure sine wave, 230 V, Single phase, 50Hz. * Efficiency: >95%. * Overloading features: 150 % for 1 min (Surge Power). * Cooling: Forced air-cooling with temperature-controlled automatic cooler fan. * Operating temperature :0 to 50 deg C. * Can work efficiently under condition relative humidity: 95% * Enclosure protection IP 54. * Protections must be provided: <ul style="list-style-type: none"> * Input voltage protection: (Undervoltage, over-voltage) * Output voltage protection: (Undervoltage, overvoltage). * DC reverse polarity. 	Pcs	1
12.4	<p>Modules Mounting Support Structure (MMSS) (to hold 14 (Pcs) of solar panels):</p> <p>Supply, Fabricated, construction, and installation of the Bolted support structure to hold modules, the support structure should be made from hot dip galvanized steel or heavy pipe & angles with precoated anti-rust as base paint & colour paint, and the Support structure withstands wind speed (40 m/sec) if the support structure it's a ground-mounted, the base of concrete (30*30*50) cm.</p>	Each	1
12.5	<p>Batteries Racks To hold (16) Pcs of batteries:</p> <p>The rack should be from Aluminium or heavy iron angles & pipe with precoated anti-rust as base painting + colour painting.</p>	Each	1
12.6	<p>Dc Cables 16 mm (rolls):</p> <p>Supply Dc cables (100 yards) single core with red colour & black colour the cables must be hosing with conduit or plastic (PVC) pipe for protection, cables shall meet the requirements of one of these certifications ISO, RoHS, IEC, and TUV.</p>	rolls	2

12.7	Junction boxes for Solar Panels with Dc Fuses: The Junction box must be manufactured from fiberglass reinforced plastic (FRP)/ thermos plastic with IP65 protection, & shall be waterproof, and dustproof. The terminals should be connected to copper bus bar arrangement of proper sizes to connect cables from solar modules arrays & Inverter. The Junction box must have protection devices below: DC -Fuses (16) Pcs (15 Amp 500 Volt) with Busbars embedded with cable glands, & conduit.	Each	1
12.8	Junction boxes for batteries with DC Circuit breakers: The Junction box must be manufactured from fiberglass reinforced plastic (FRP)/ thermos plastic with IP65 protection, & shall be waterproof, and dustproof. The terminals should be connected to copper bus bar arrangement of proper sizes to connect cables between Batteries & Inverter. The Junction box must have protection devices below: DC Circuit Breakers (6) Pcs 500 Volt, 500 Amperes with Busbars embedded in addition to that cable glands, & conduit.	Each	1
12.9	Interconnection Cables: Dc cables 25 mm, ready-made jumpers. For interconnections batteries.	Each	1
12.10	Fencing: Providing & construct galvanized iron poles 2-inch Dim, height 2 m with concrete Base 30*30*40 cm with chain-link wire with a secure distance of 3.5 m for each direction (distance between fence & solar panels).	Work	1
12.11	Accessories: Nuts, clips, tapes cables clamps ...etc.	Job	1
12.12	Lighting arrester& earthing: Has cable 16 mm, 20 Meters, Star, equipotential busbar, earthing rods, set of joint cable, set of screws to the joint module via support structure.	Set	1
12.13	Installation & testing & commission of solar system above.	Work	1

5. Site Drawings:

Below are the drawings:



General location

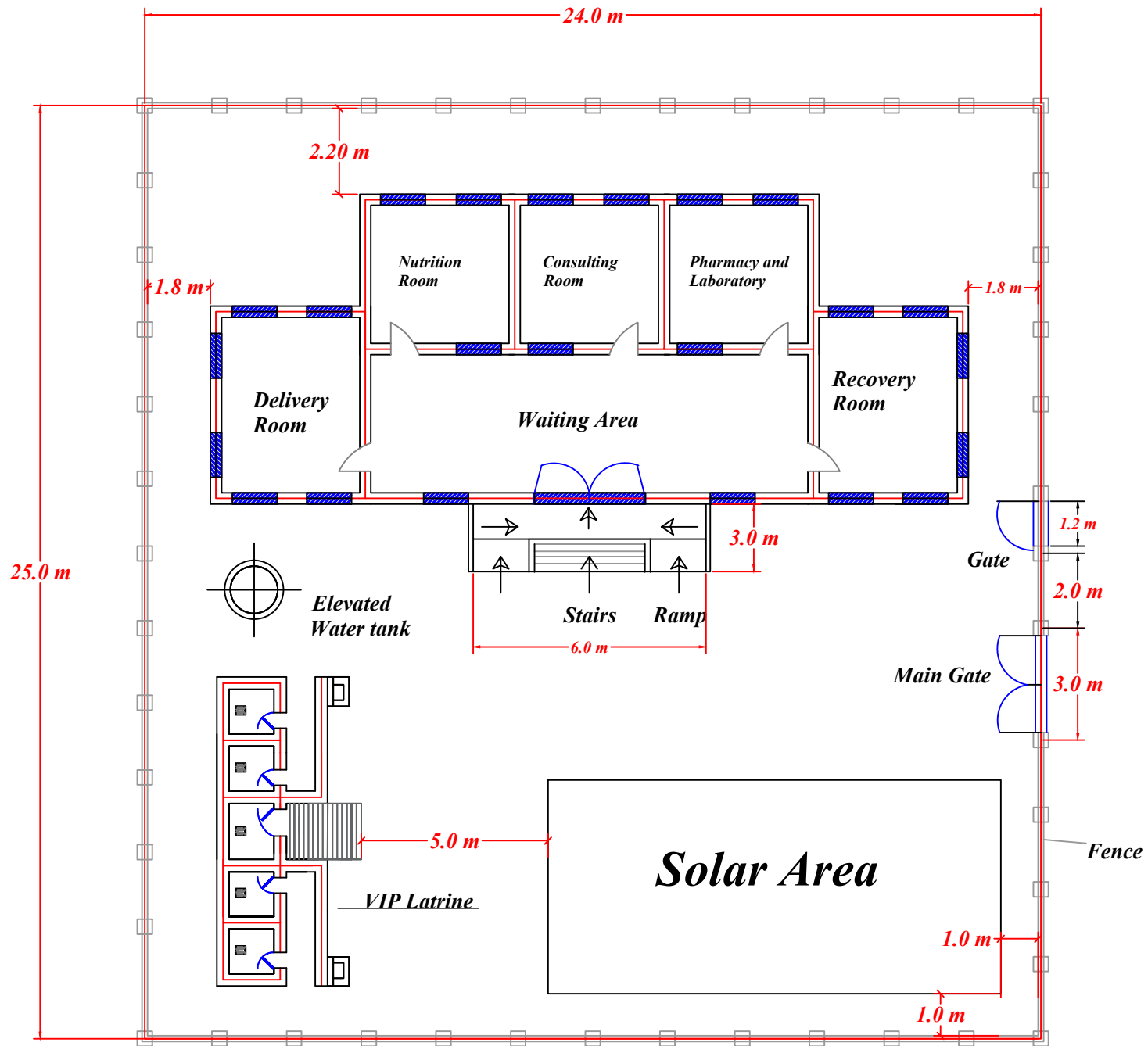

General notes:

- 1- All dimensions in meters unless stated.
- 2- Don't scale from this drawing.
- 3- Any description found in the drawing is to be immediately brought to the notice and clarified with the main designer or supply unit.

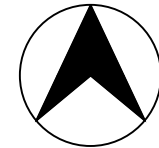

Project Title:

Motherhood & Childhood care center

Drawing Title:

General layout



UNHCR
The UN Refugee Agency

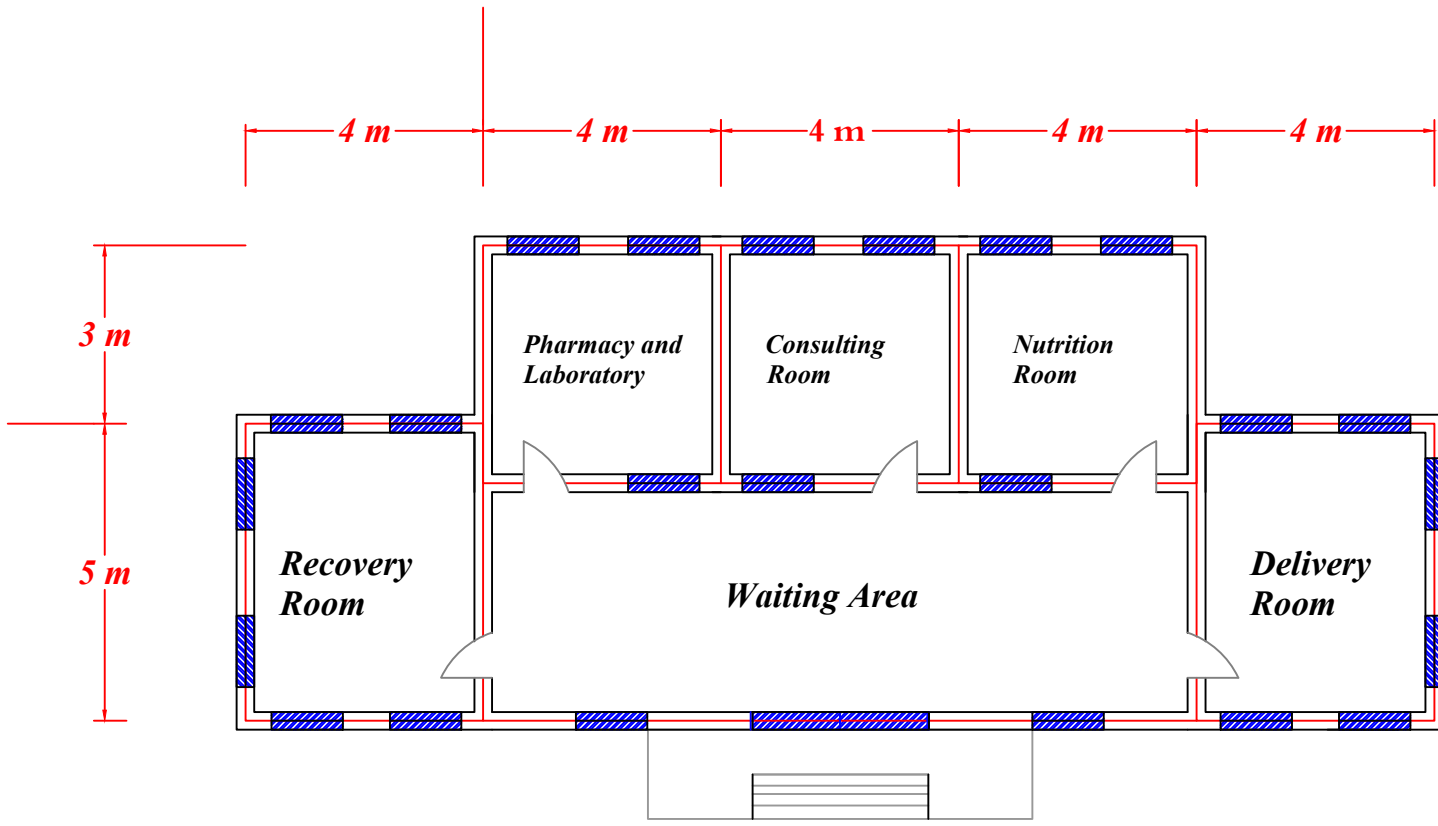

General notes:

- 1- All dimensions in meters unless stated.
- 2- Don't scale from this drawing.
- 3- Any description found in the drawing is to be immediately brought to the notice and clarified with the main designer or supply unit.

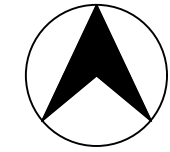

Project Title:

Motherhood & Childhood care center

Drawing Title:

Rooms layout



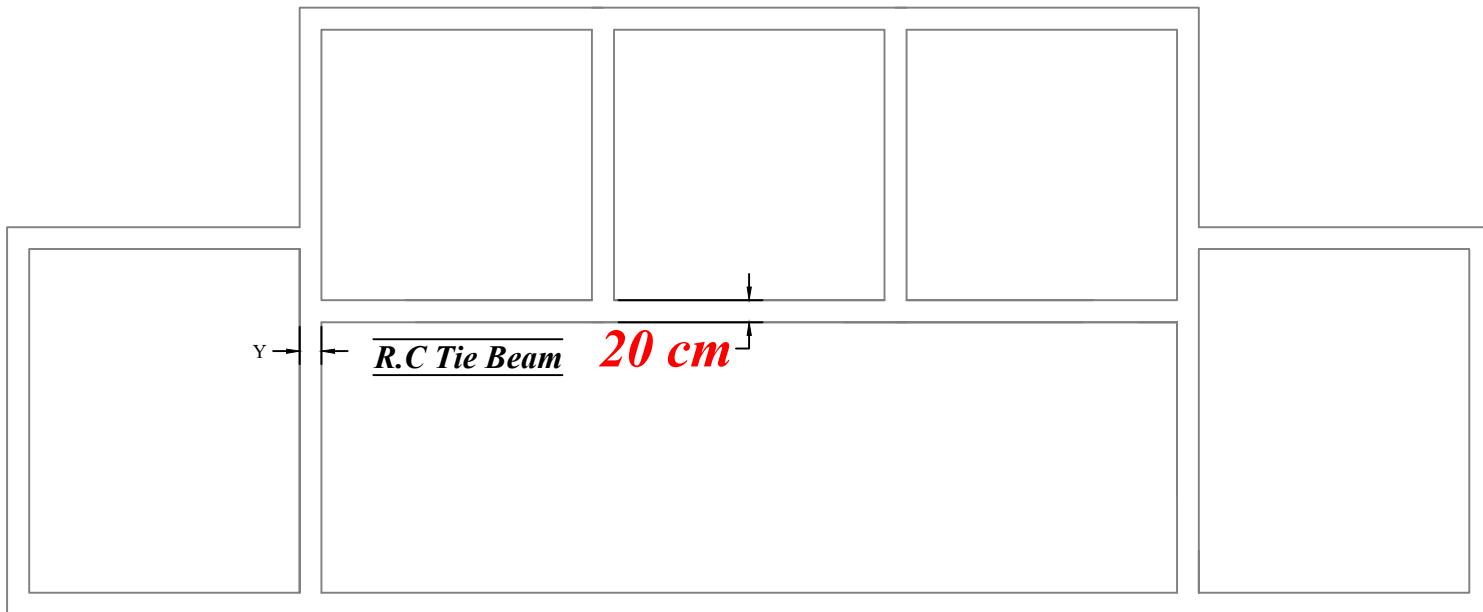

General notes:

- 1- All dimensions in meters unless stated.
- 2- Don't scale from this drawing.
- 3- Any description found in the drawing is to be immediately brought to the notice and clarified with the main designer or supply unit.
- 4- Concrete for Tie beam 1:2:4 ratio with 20x30 cm with 12mm steel bar and use 8 mm for stirrups

Project Title:

Motherhood & Childhood care center

Drawing Title:

Reinforced concrete Tie beam



UNHCR
The UN Refugee Agency

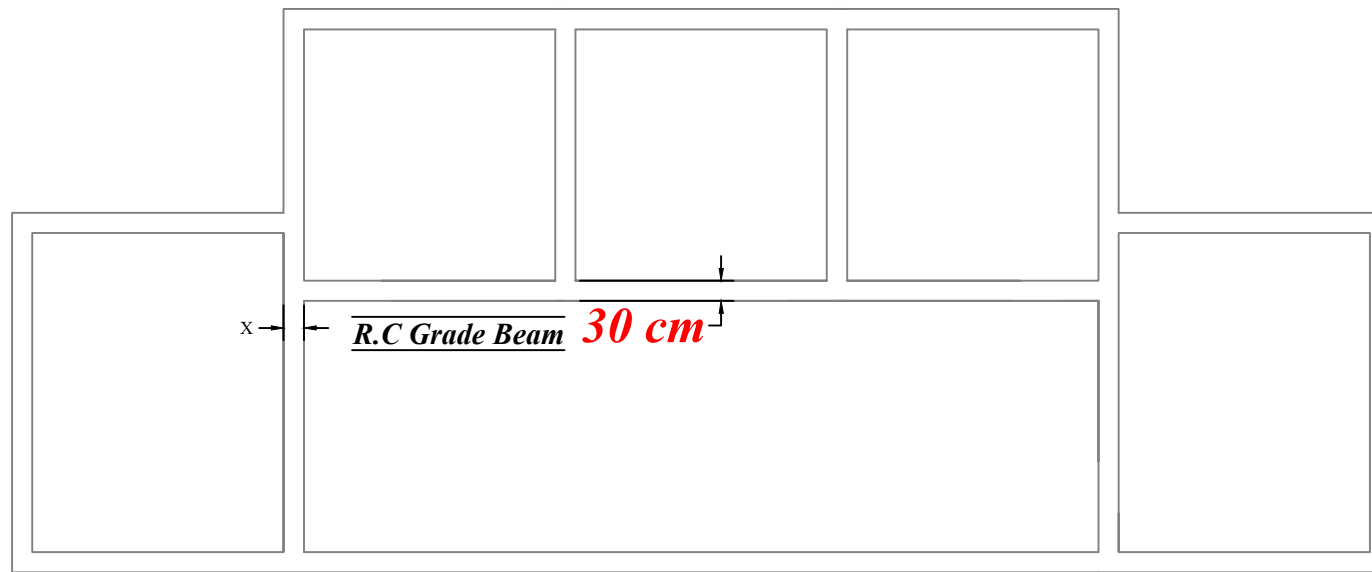

General notes:

- 1- All dimensions in meters unless stated.
- 2- Don't scale from this drawing.
- 3- Any description found in the drawing is to be immediately brought to the notice and clarified with the main designer or supply unit.
- 4- Concrete for Grade beam 1:2:4 ratio with 40x30 cm with 12mm steel bar and use 8 mm for stirrups

Project Title:

Motherhood & Childhood care center

Drawing Title:

Reinforced concrete Grade beam



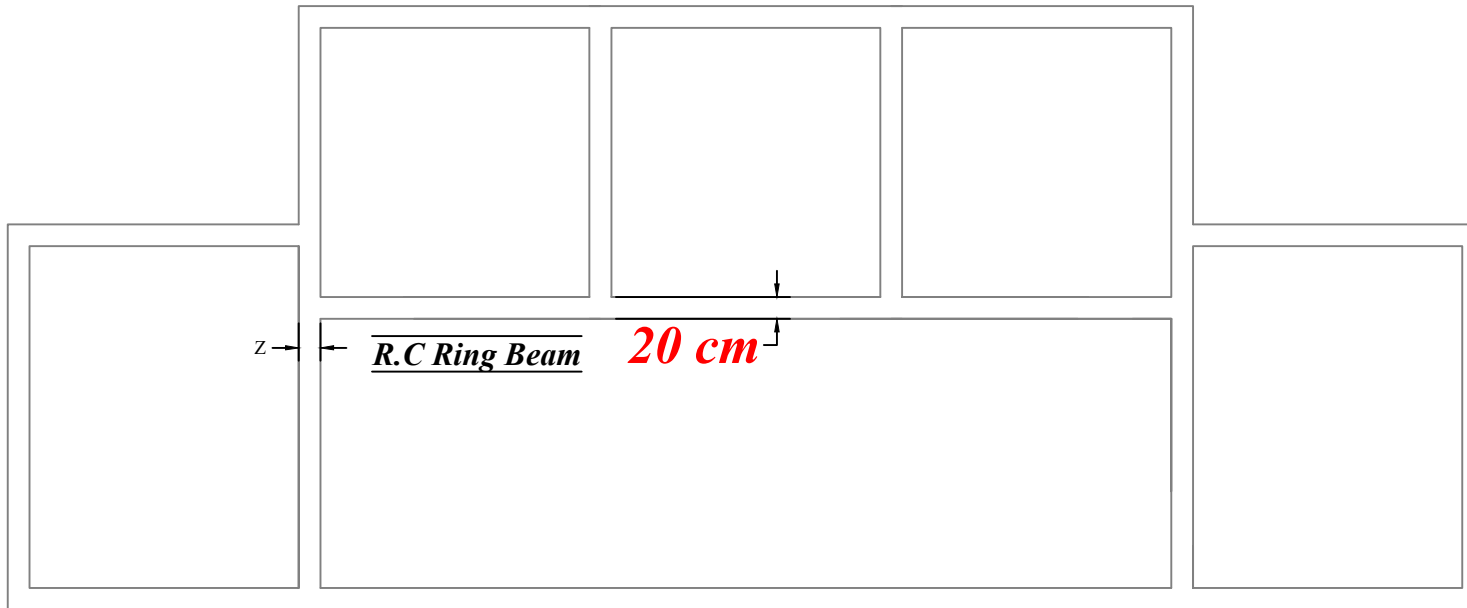

General notes:

- 1- All dimensions in meters unless stated.
- 2- Don't scale from this drawing.
- 3- Any description found in the drawing is to be immediately brought to the notice and clarified with the main designer or supply unit.
- 4- Concrete for Ring beam 1:2:4 ratio with 20x30 cm with 12mm steel bar and use 8 mm for stirrups

Project Title:

Motherhood & Childhood care center

Drawing Title:

Reinforced concrete Ring beam



UNHCR
The UN Refugee Agency

General notes:

- 1- All dimensions in meters unless stated.
- 2- Don't scale from this drawing.
- 3- Any description found in the drawing is to be immediately brought to the notice and clarified with the main designer or supply unit.

KEY LEGEND	
ITEM	DESCRIPTION
⊕	Ceiling Lamp
⊗	Ceiling Fan
⊕	Wall Lamp
■	Lamp Key
□	Socket
⊗	Control panel

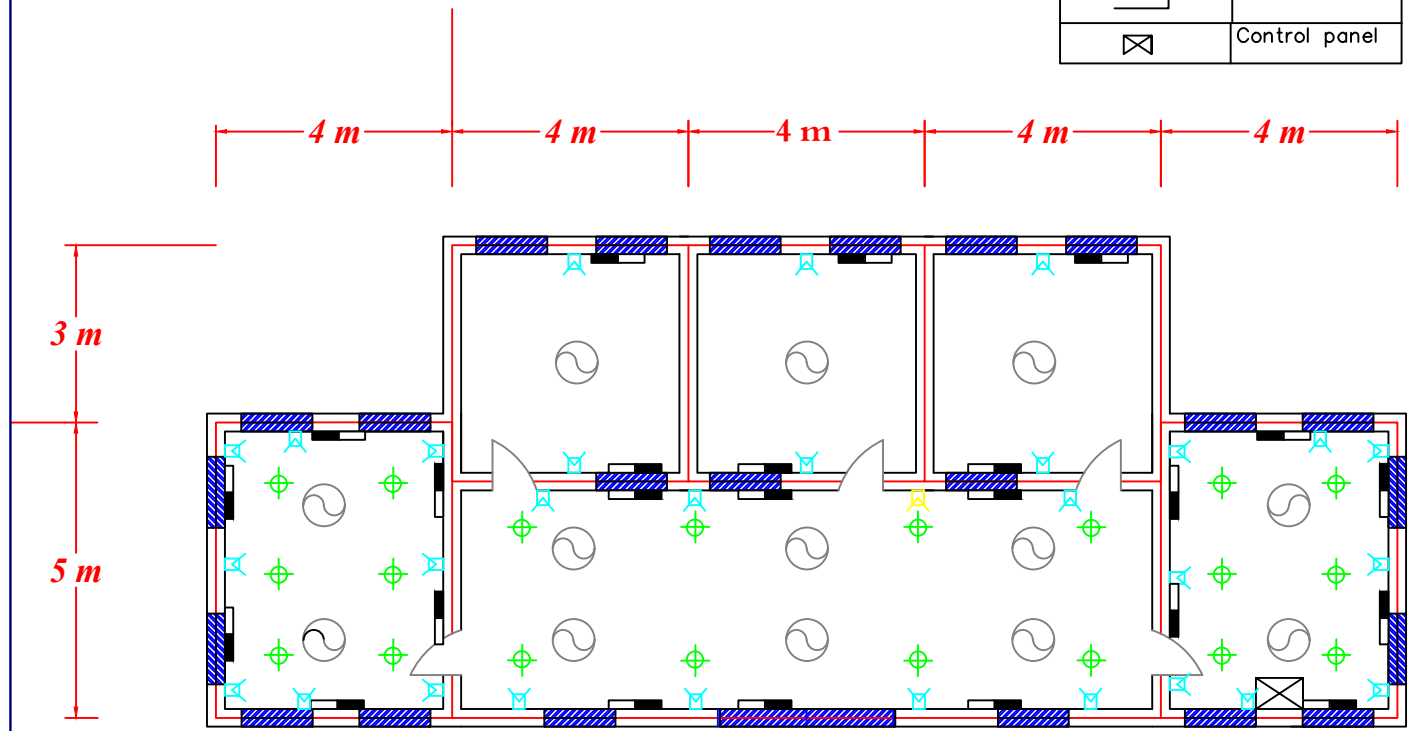

Project Title:

Motherhood & Childhood care center

Drawing Title:

Electrical details



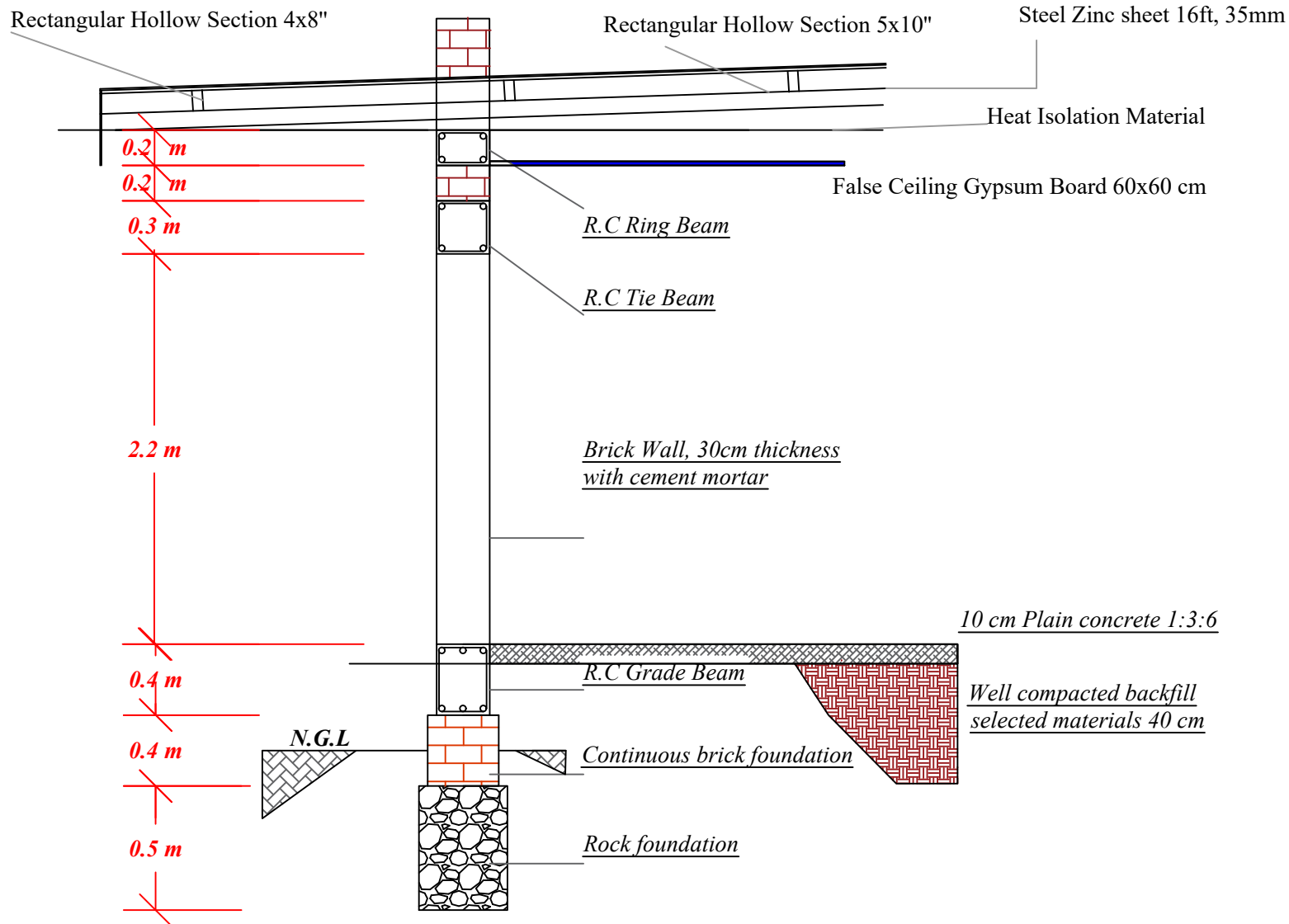

General notes:

- 1- All dimensions in meters unless stated.
- 2- Don't scale from this drawing.
- 3- Any description found in the drawing is to be immediately brought to the notice and clarified with the main designer or supply unit.

Project Title:

Motherhood & Childhood care center

Drawing Title:

Reinforced Wal section



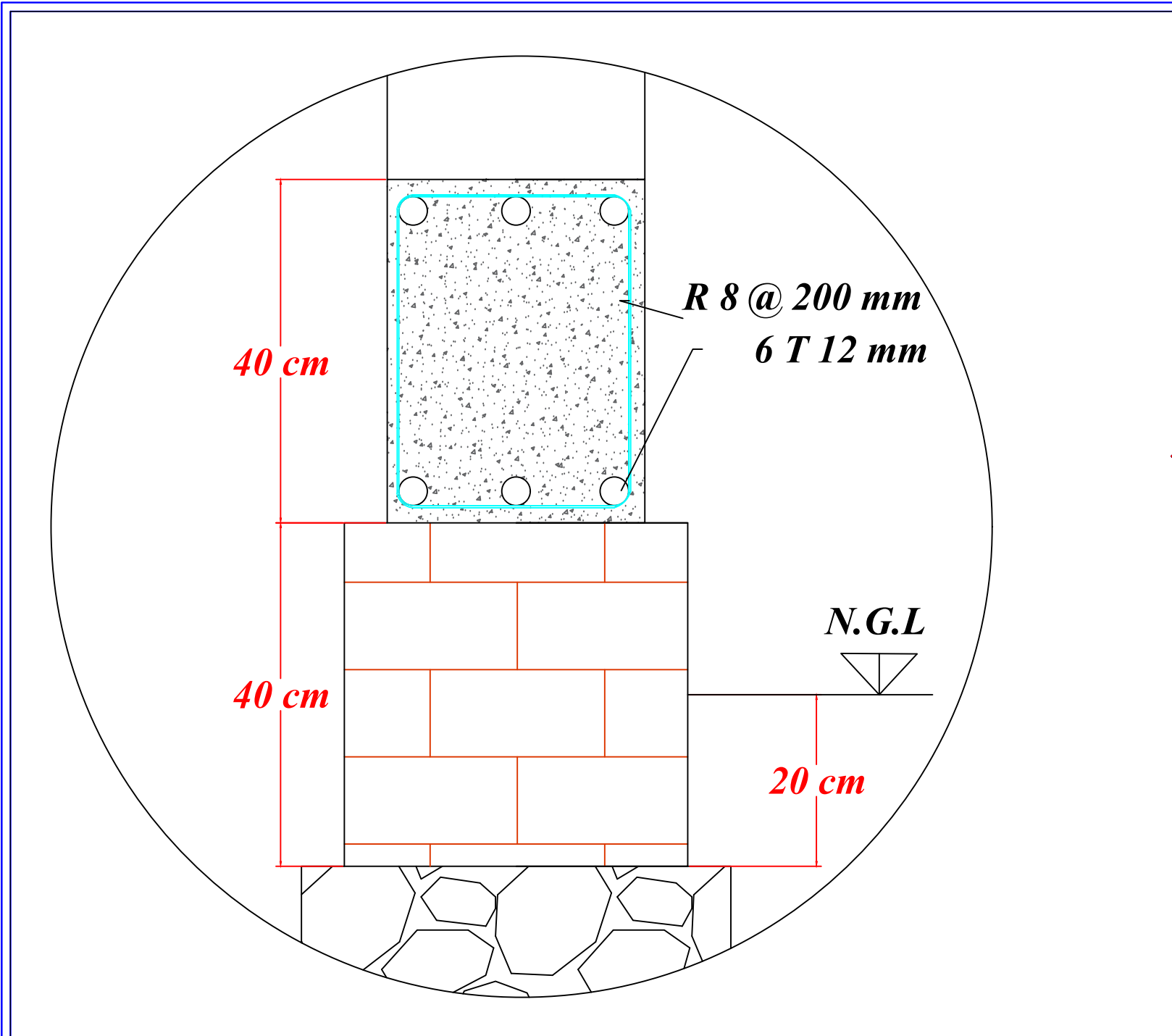

General notes:

- 1- All dimensions in meters unless stated.
- 2- Don't scale from this drawing.
- 3- Any description found in the drawing is to be immediately brought to the notice and clarified with the main designer or supply unit.

Project Title:

Motherhood & Childhood care center

Drawing Title:

Reinforced Wall section detail 1



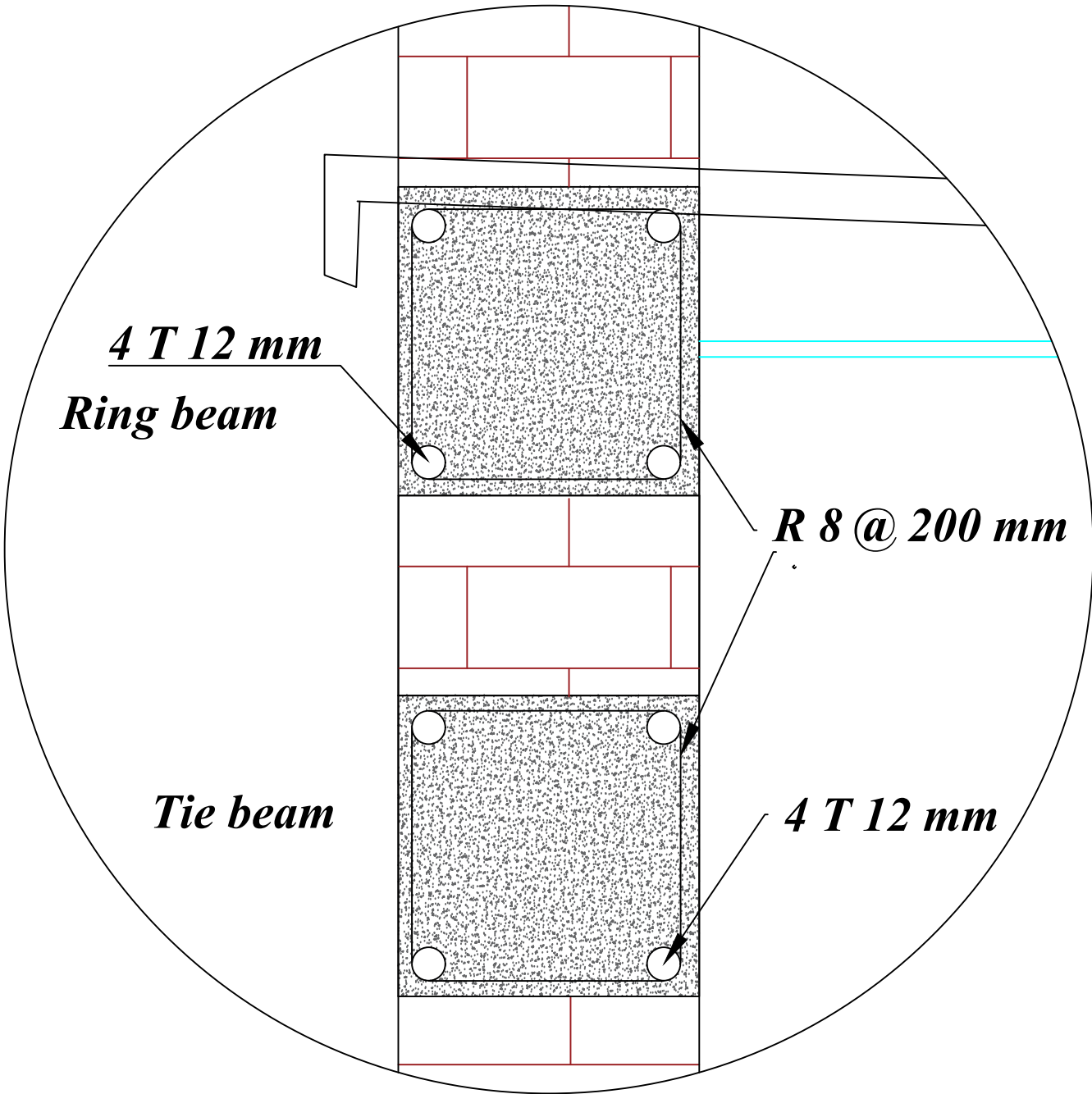

General notes:

- 1- All dimensions in meters unless stated.
- 2- Don't scale from this drawing.
- 3- Any description found in the drawing is to be immediately brought to the notice and clarified with the main designer or supply unit.

Project Title:

Motherhood & Childhood care center

Drawing Title:

Reinforced Wall section detail 2



1.2 m 1.2 m 1.5 m 1.2 m 1.2 m

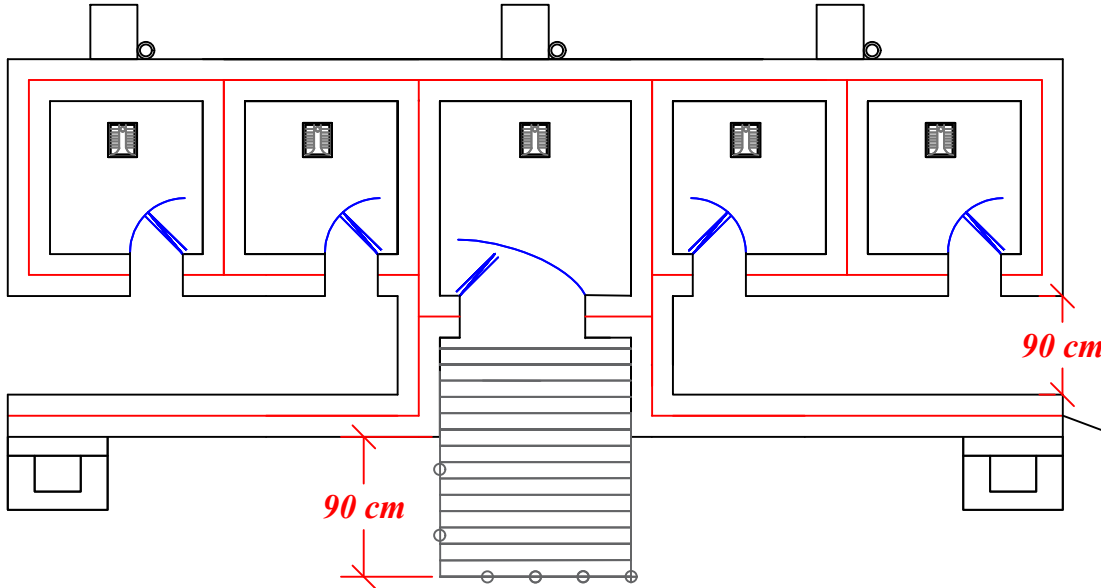

Ramp with 1:0.08 slope

**Privacy wall
with 1.5m
height**

General notes:

- 1- All dimensions in meters unless stated.
- 2- Don't scale from this drawing.
- 3- Any description found in the drawing is to be immediately brought to the notice and clarified with the main designer or supply unit.

Project Title:

Motherhood & Childhood care center

Drawing Title:

Latrine- Plan



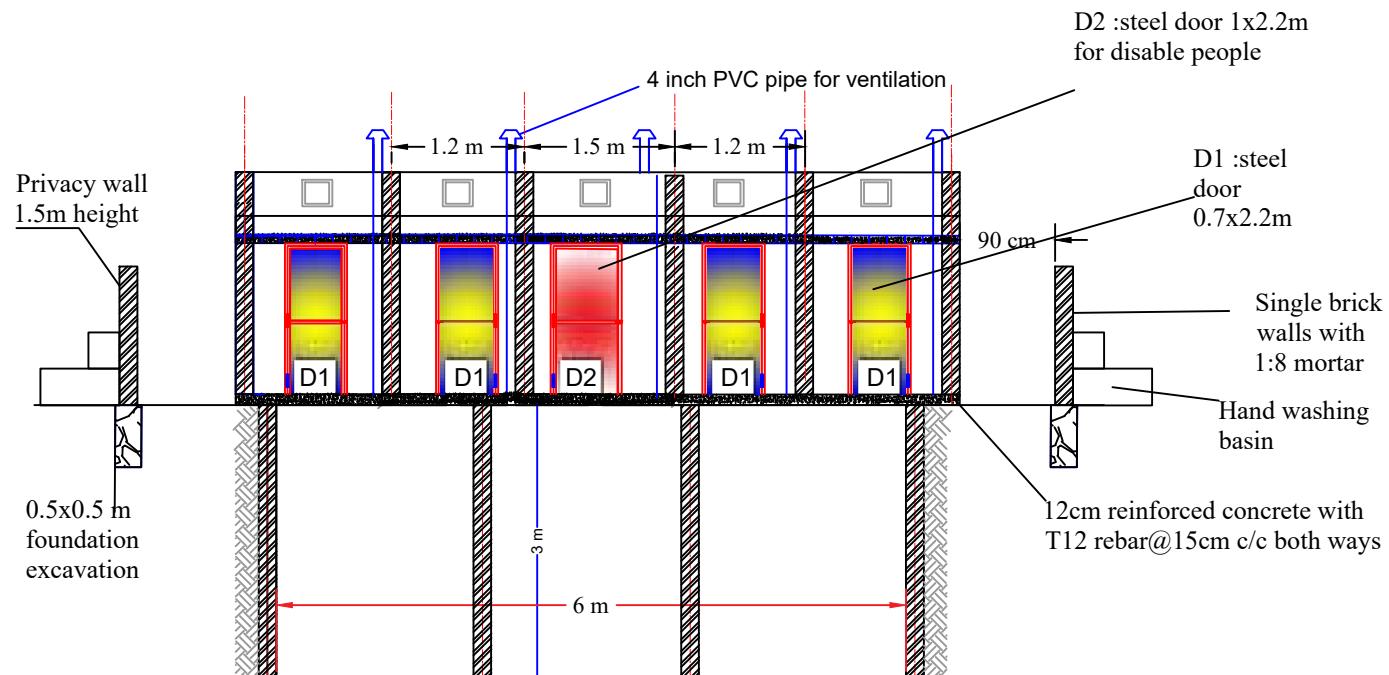

General notes:

- 1- All dimensions in meters unless stated.
- 2- Don't scale from this drawing.
- 3- Any description found in the drawing is to be immediately brought to the notice and clarified with the main designer or supply unit.

Project Title:

Motherhood & Childhood care center

Drawing Title:

Latrine front view



UNHCR
The UN Refugee Agency

General notes:

- 1- All dimensions in meters unless stated.
- 2- Don't scale from this drawing.
- 3- Any description found in the drawing is to be immediately brought to the notice and clarified with the main designer or supply unit.

Project Title:

Motherhood & Childhood care center

Drawing Title:

Latrine side view

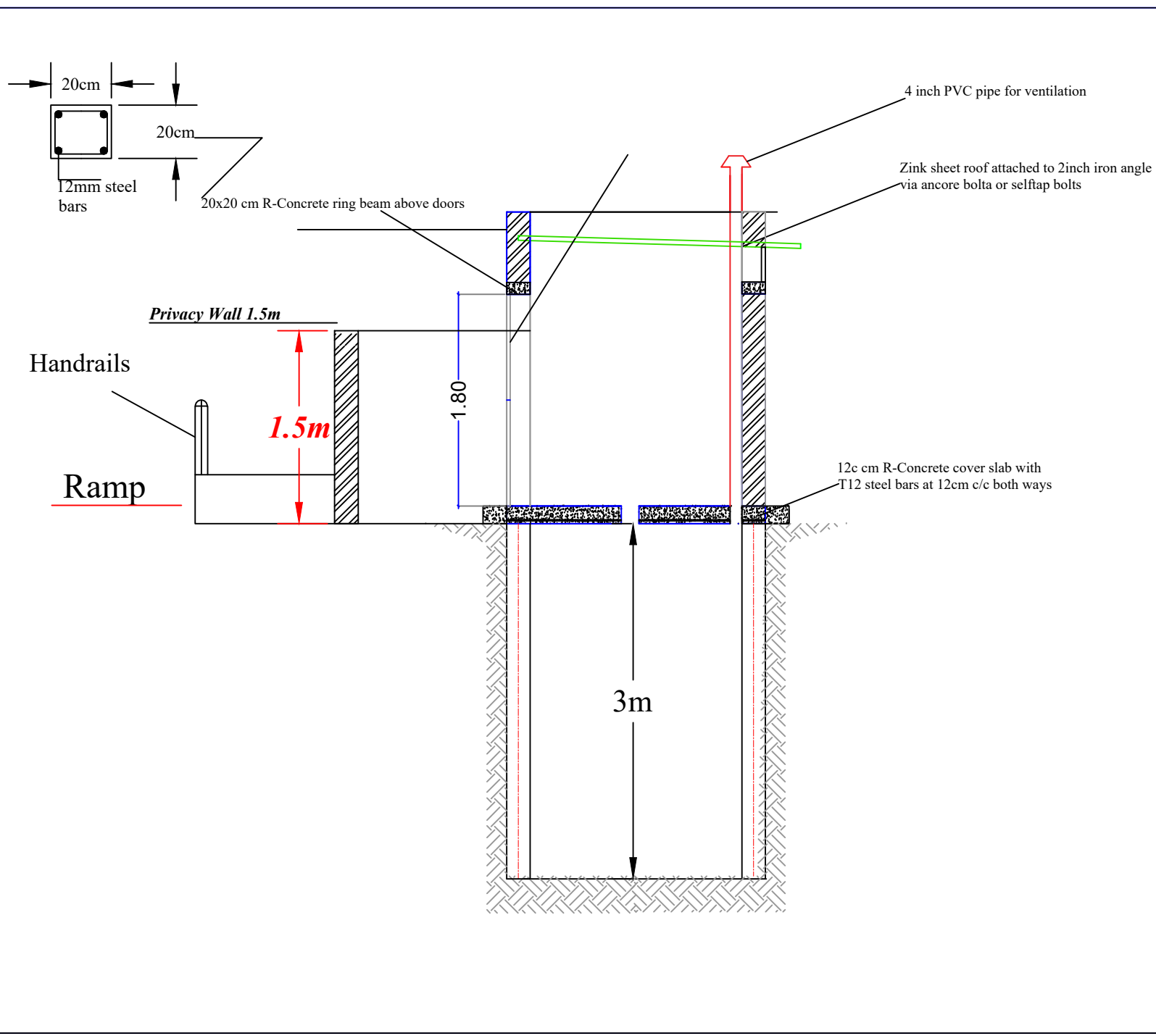

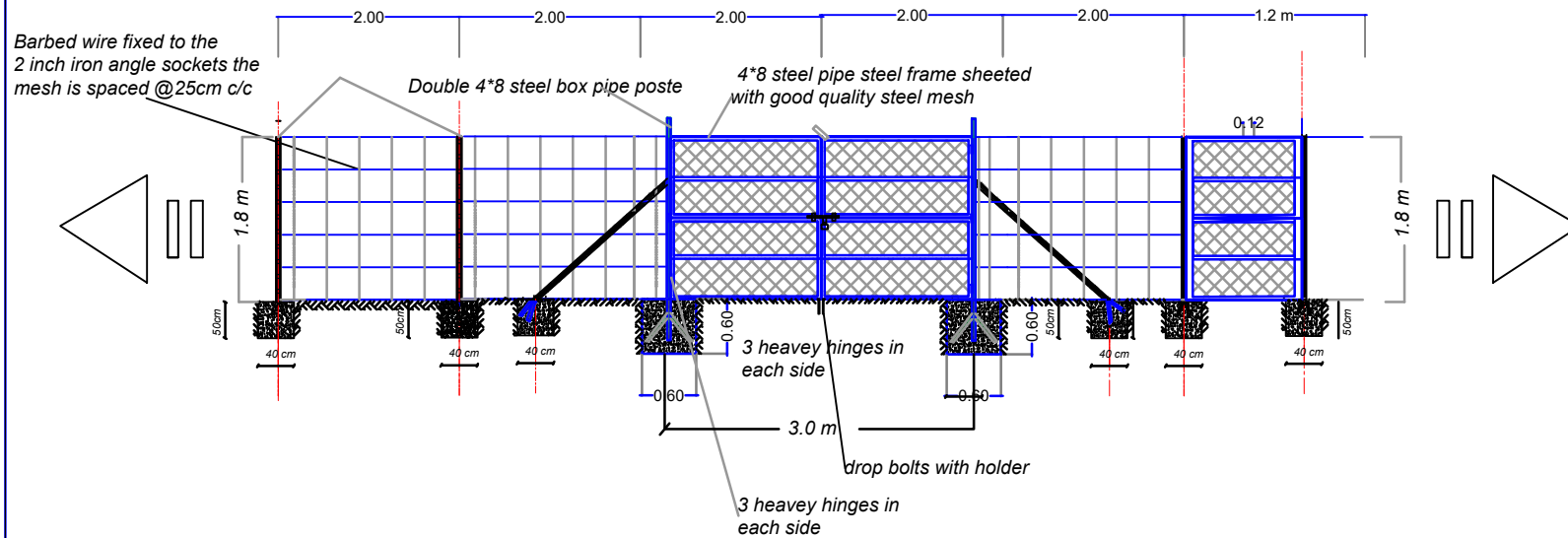
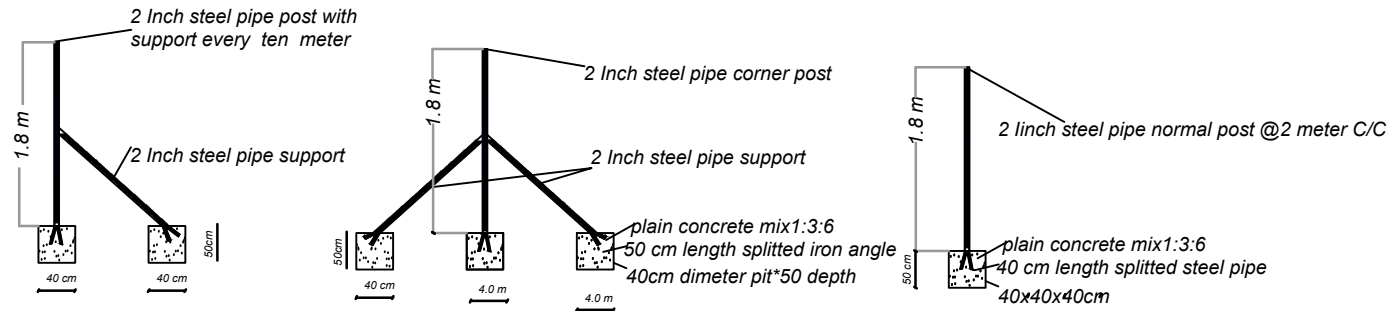

General notes:

- 1- All dimensions in meters unless stated.
- 2- Don't scale from this drawing.
- 3- Any description found in the drawing is to be immediately brought to the notice and clarified with the main designer or supply unit.

Project Title:

Motherhood & Childhood care center

Drawing Title:

Fence section detail 1



UNHCR
The UN Refugee Agency

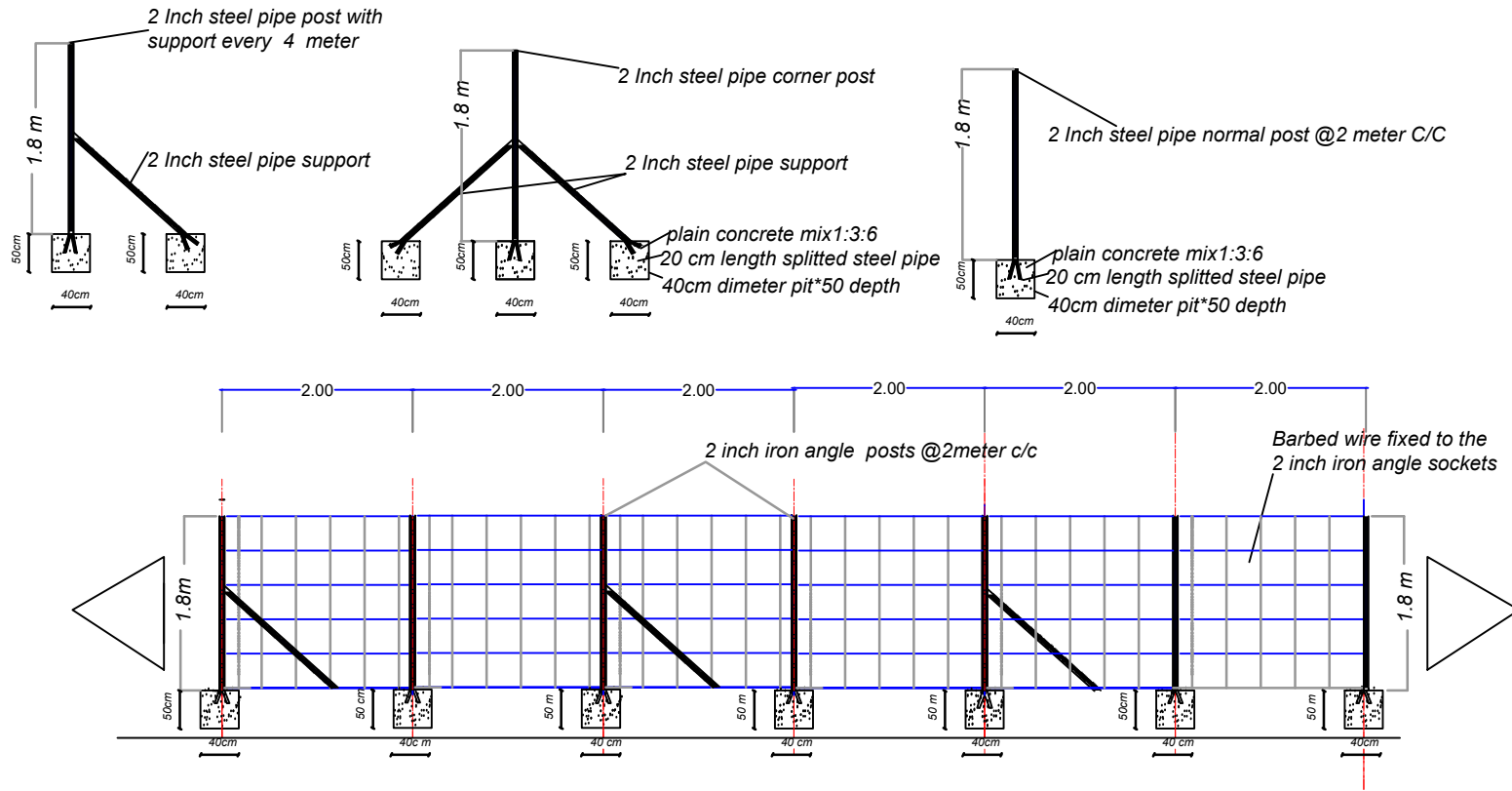

General notes:

- 1- All dimensions in meters unless stated.
- 2- Don't scale from this drawing.
- 3- Any description found in the drawing is to be immediately brought to the notice and clarified with the main designer or supply unit.

Project Title:
Motherhood & Childhood care center

Drawing Title:
Fence section detail 2

